

Part Number:

1990630 - Stainless Steel
1990631 - Black

Models:

Classic 350cc, Classic 500cc

WARNING: Royal Enfield genuine accessories are designed to fit only the specific Royal Enfield motorcycle(s) that are specified above. They should not be fitted to any other type of motorcycle. Pay particular attention to the warnings and cautions contained in this instruction, failure to do so may result in an incorrect installation of the accessory which could result in an unsafe riding condition and possible accident. If in any doubt always seek the help from your authorised Royal Enfield dealer.

WARNING: Before starting any accessory kit installation ensure the motorcycle is supported in a stable condition. Failure to support the motorcycle correctly could lead to motorcycle damage or personal injury.

WARNING: All fixings must be tightened to the torque values specified in this instruction. Failure to tighten fixings to the correct torque could result in an unsafe riding condition and possible accident.

CAUTION: Care should be taken when fitting any accessory kit. Incorrect handling kit components or the use of incorrect tools could lead to component or motorcycle damage.

NOTE: The content of this instruction is subject to change at any time without notice or liability. Royal Enfield reserves the right to revise the information presented at any time.

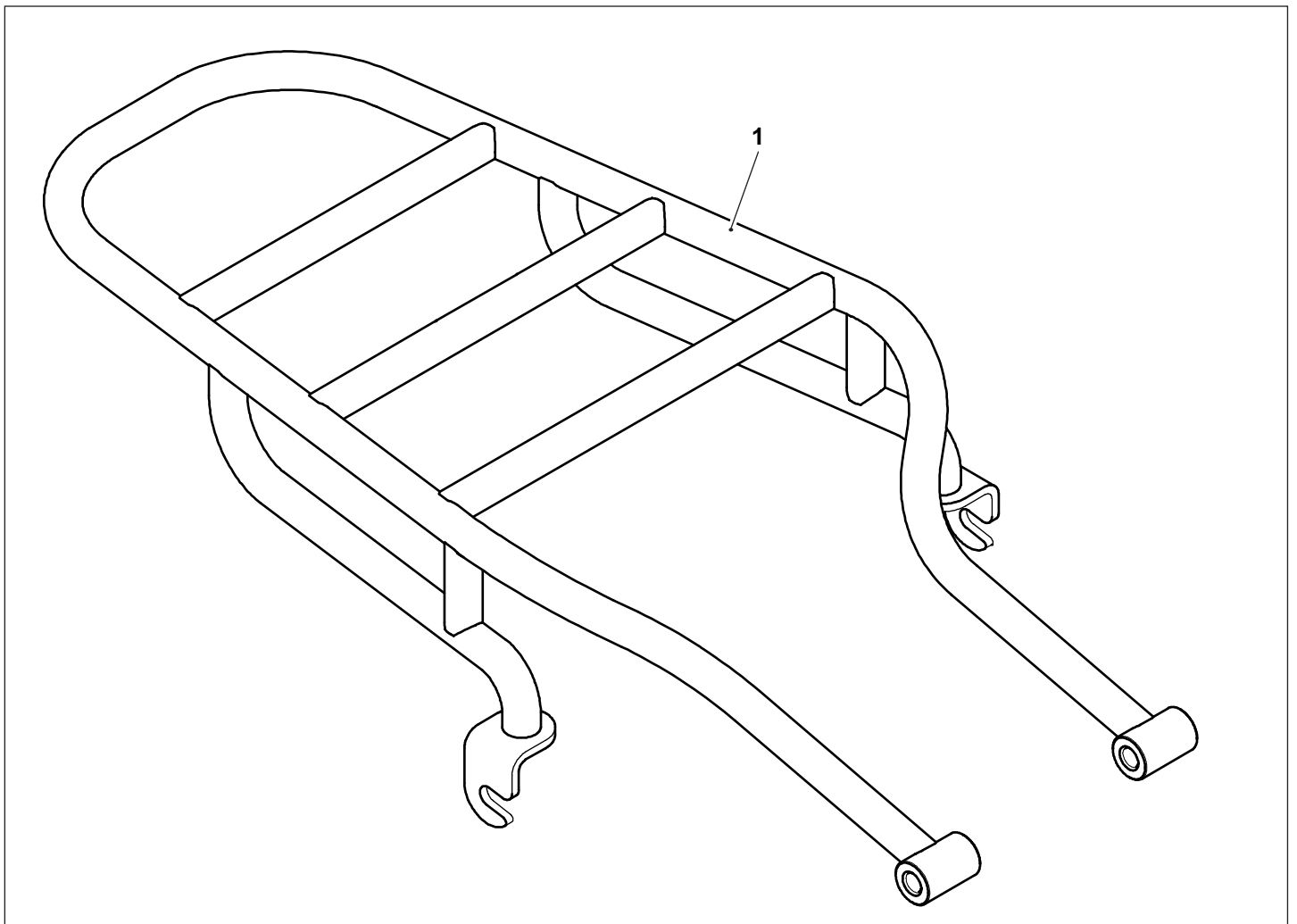

Item	Description	Qty
1	Luggage rack	1

1 Remove the passenger seat mounting bracket front fixing (1) from the right hand side of the motorcycle. Retain the fixing for reuse.

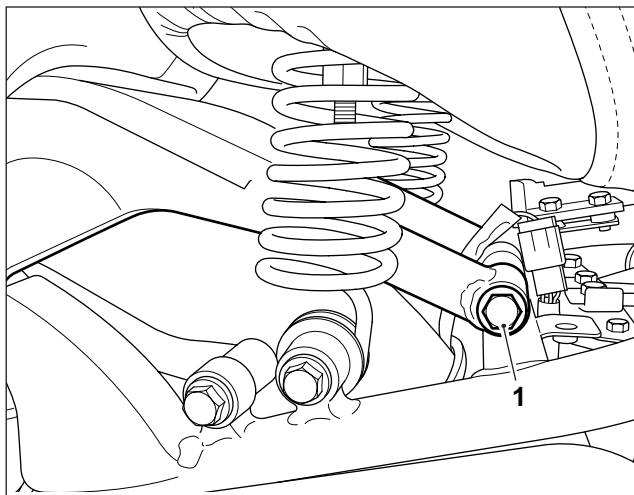

2 Loosen the top rear suspension mounting nuts (1) on both sides of the motorcycle, right hand side shown. Do not remove the rear suspension mounting nuts.

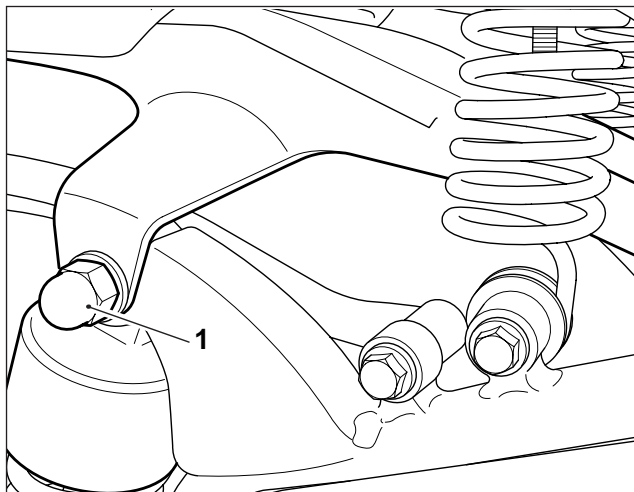

3 Carefully slide the passenger seat assembly (1) towards the rear of the motorcycle to disengage the seat mounting bracket (2) from the rear suspension fixings (3), right hand side shown. Remove the passenger seat assembly from the motorcycle. Retain the passenger seat assembly for reuse if the accessory luggage rack is removed.

CAUTION: When removing the passenger seat and mounting bracket assembly ensure the assembly is kept clear of the rear mudguard. If the passenger seat and mounting bracket assembly are allowed to contact the rear mudguard it could result in damage to the mudguard finish.

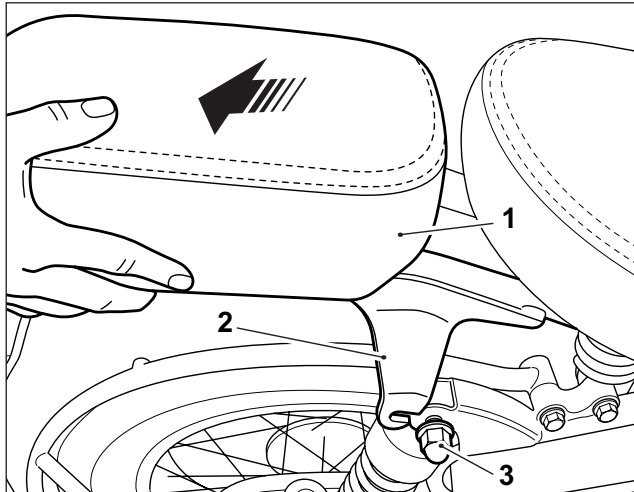

4 Carefully position the luggage rack front mounting bracket (1) under the rider seat and locate the mounting bracket correctly on the frame mounting (2).

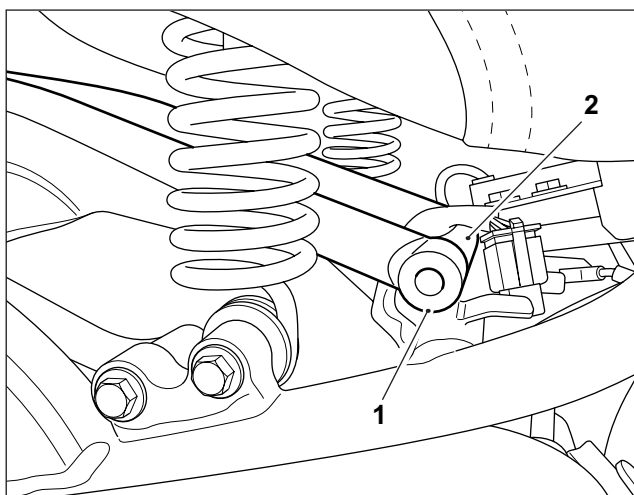

5 Lower the luggage rack (1) and slide the rack forwards to engage the mounting brackets (2) on the rear suspension fixings (3), right hand side shown. Ensure the mounting brackets are located behind the washers (4) on the rear suspension fixings, as shown.

 **CAUTION:** When fitting the luggage rack ensure it is kept clear of the rear mudguard. If the luggage rack is allowed to contact the rear mudguard it could result in damage to the mudguard finish.

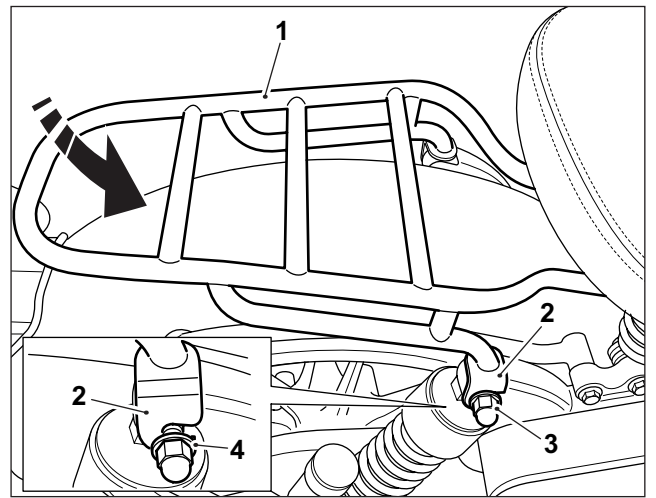

6 Align the front fixing positions of the luggage rack (1) with the mounting position on the motorcycle frame (2).

Fit the original fixing (3) from the right hand side of the motorcycle. Tighten the fixing to **25 Nm**.

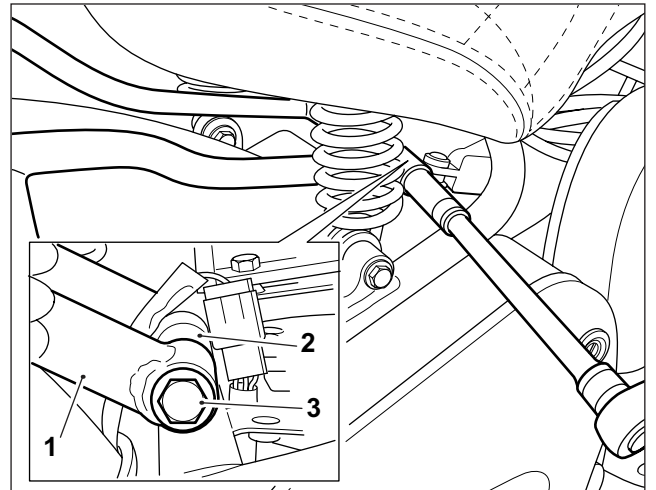

7 Tighten the rear suspension fixings (1) on both sides of the motorcycle to **40 Nm**, right hand side shown.

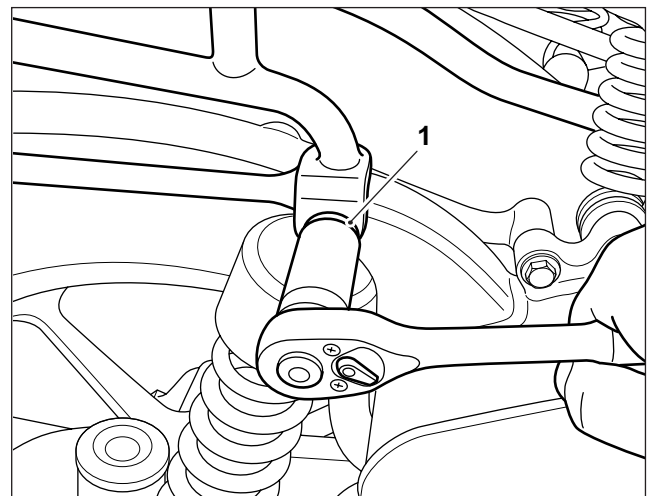

 **WARNING:** Always ensure that any load carried on a luggage rack is correctly secured and will not move when the motorcycle is ridden. The maximum safe load for the luggage rack is 5 kg (11 lbs). Incorrect, or over loading the luggage rack may cause the motorcycle to become unstable and result in an accident.

 **WARNING:** After fitting any genuine Royal Enfield accessory always ride the motorcycle with caution and allow time to become familiar with any change in the motorcycle handling characteristics. Failure to become familiar with any change in the motorcycle handling characteristics may cause the motorcycle to become unstable and result in an accident.