

Part Number:

1990406 & 1990408 (Compact)
1990407 & 1990427 (Large)

Models :

Continental (2018 onwards)
Interceptor (2018 onwards)

WARNING: Royal Enfield genuine accessories are designed to fit only the specific Royal Enfield motorcycle(s) that are specified above. They should not be fitted to any other type of motorcycle. Pay particular attention to the warnings and cautions contained in this instruction, failure to do so may result in an incorrect installation of the accessory which could result in an unsafe riding condition and possible accident. If in any doubt always seek the help from your authorised Royal Enfield dealer.

WARNING: Before starting any accessory kit installation ensure the motorcycle is supported in a stable condition. Failure to support the motorcycle correctly could lead to motorcycle damage or personal injury.

WARNING: All fixings must be tightened to the torque values specified in this instruction. Failure to tighten fixings to the correct torque could result in an unsafe riding condition and possible accident.

CAUTION: Care should be taken when fitting any accessory kit. Incorrect handling kit components or the use of incorrect tools could lead to component or motorcycle damage.

NOTE: The content of this instruction is subject to change at any time without notice or liability. Royal Enfield reserves the right to revise the information presented at any time.

Compact: 1990406, 1990408

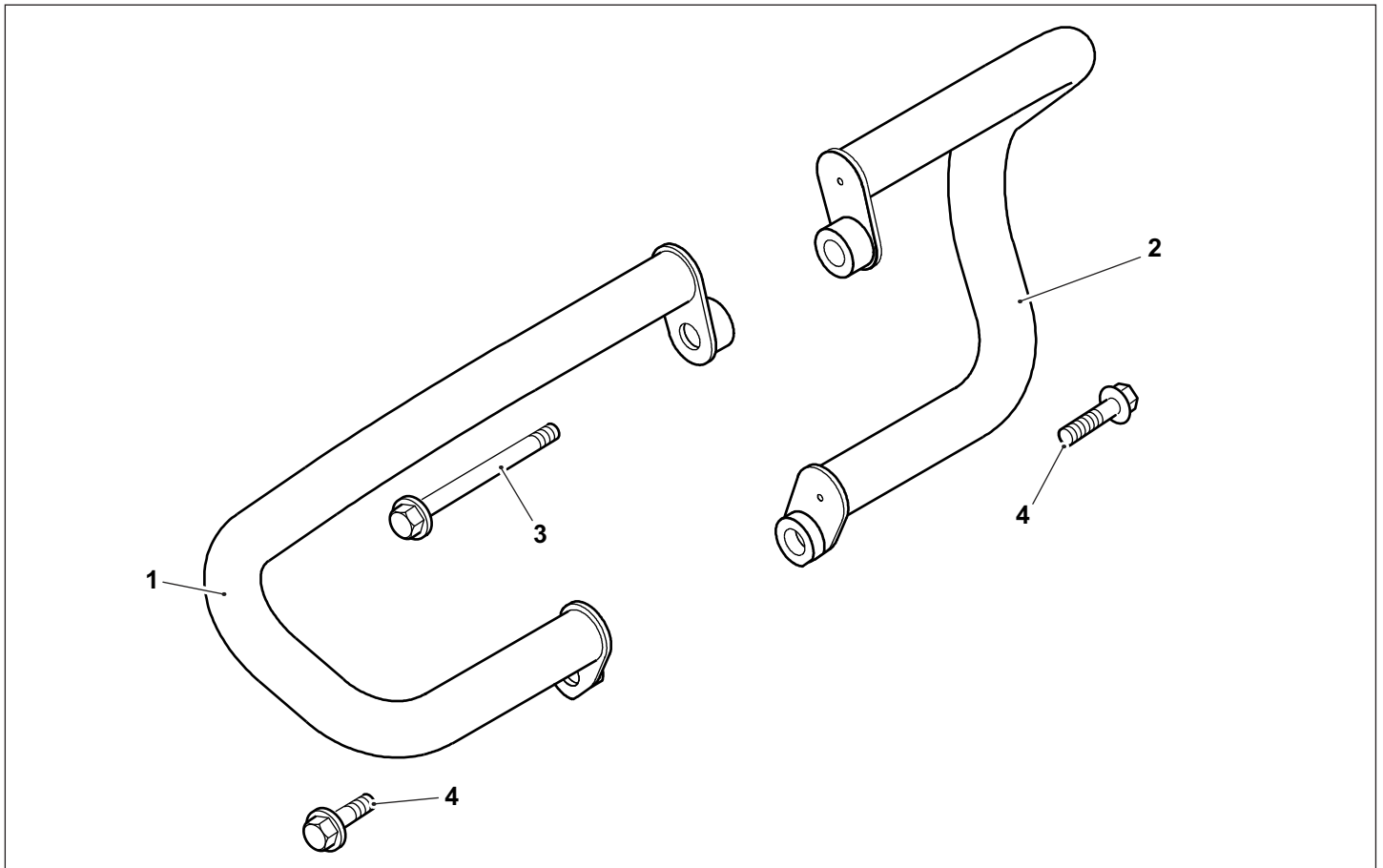

| Item | Description | Qty |
|------|-----------------------------------|-----|
| 1 | Engine guard assembly, right hand | 1 |
| 2 | Engine guard assembly, left hand | 1 |
| 3 | Fixing, M10 x132mm | 1 |
| 4 | Fixing, M10 x 52mm | 2 |

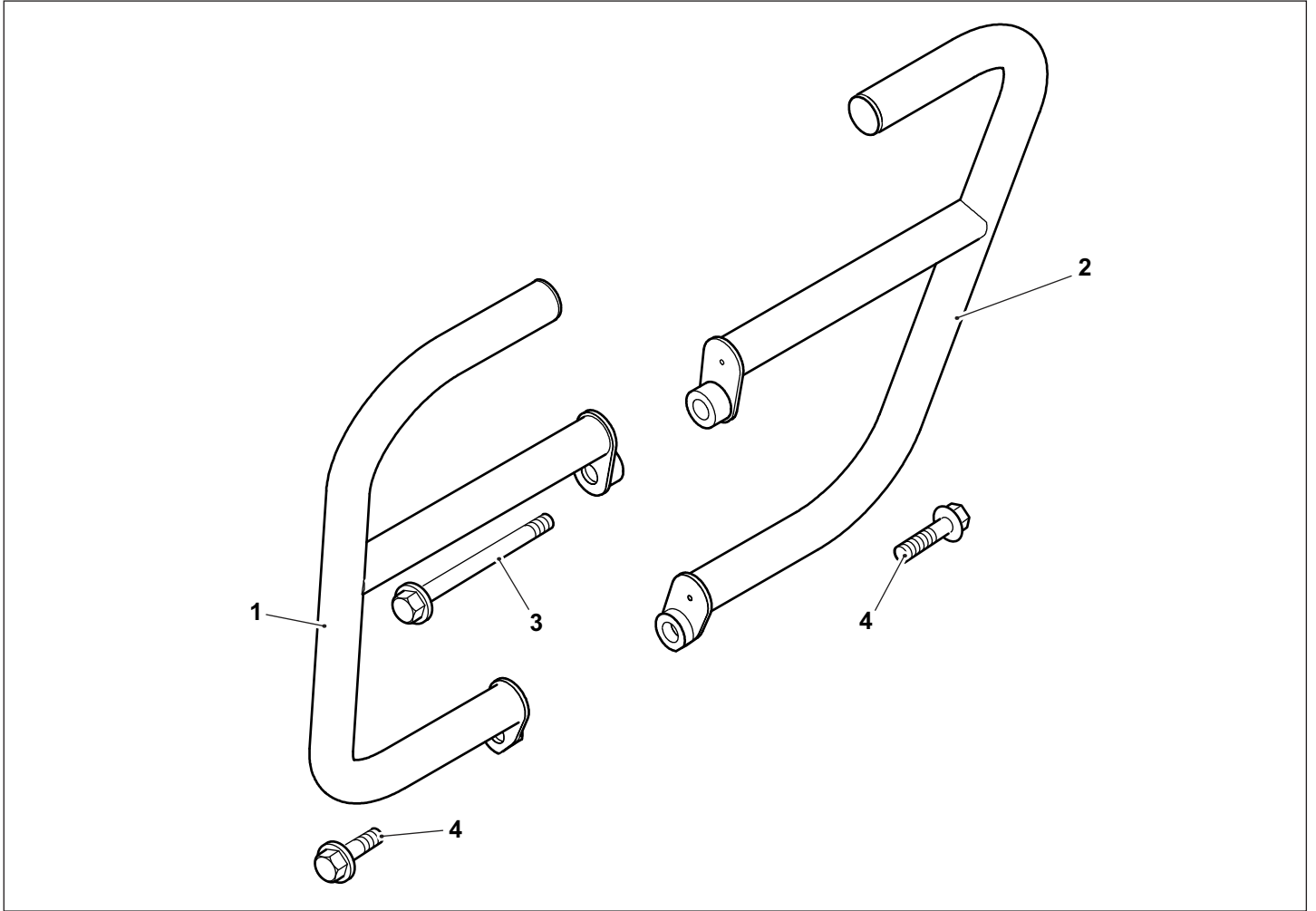

| Item | Description | Qty |
|------|-----------------------------------|-----|
| 1 | Engine guard assembly, right hand | 1 |
| 2 | Engine guard assembly, left hand | 1 |
| 3 | Fixing, M10 x132mm | 1 |
| 4 | Fixing, M10 x 52mm | 2 |

NOTE: Although the shape of the Compact and Large engine guards are different, the method of fitment is the same for both types.

WARNING: If the engine has recently been running the exhaust system will be hot. Before working near to the exhaust system always allow time for the exhaust system to cool. Touching any part of a hot exhaust system will cause burn injuries.

1 Remove the top engine mounting fixing nut (1) and washer (2) from the right hand side of the motorcycle. Retain the nut and washer for reuse.

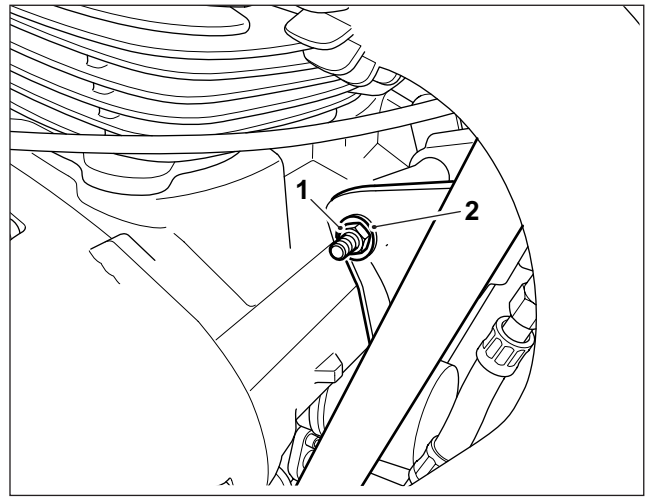

2 Remove the top engine mounting fixing (1) and washer (2) from the left hand side of the motorcycle. Retain the fixing and washer for reuse if the engine guards are to be removed.

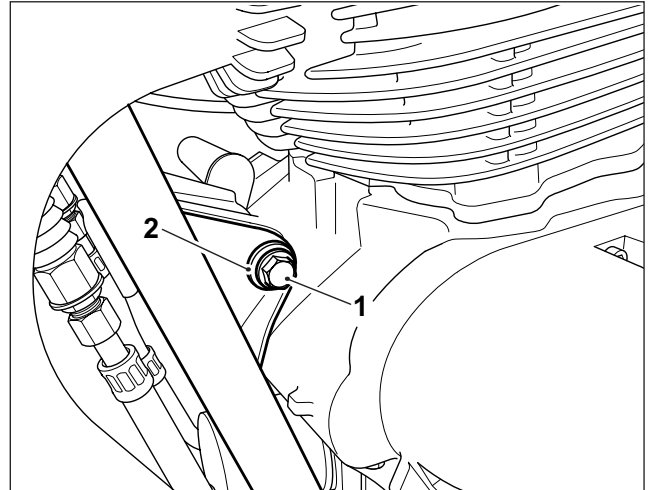

3 Remove the front lower engine mounting fixings (1) washers (2), nuts (3) and washers (4) from the left hand and right hand side of the motorcycle. Retain the nuts (3) and washers (4) for reuse. Retain the fixings (1) and washers (2) for reuse if the engine guards are to be removed.

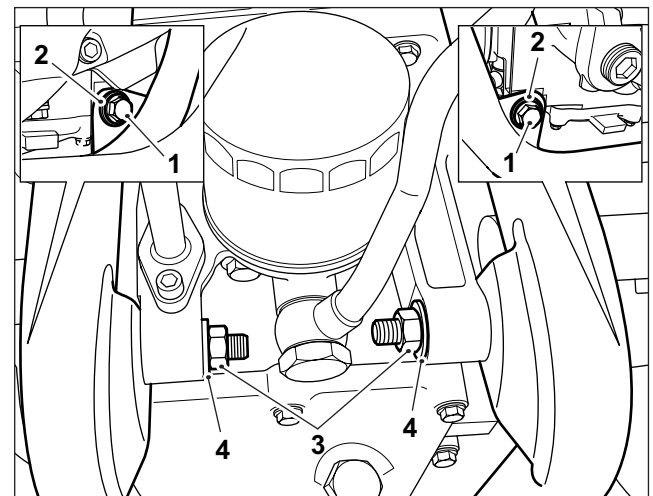

4 Align the top mounting of the left hand engine guard (1) with the top engine mounting location and fit the M10 x 132mm fixing (2) from the kit, as shown.

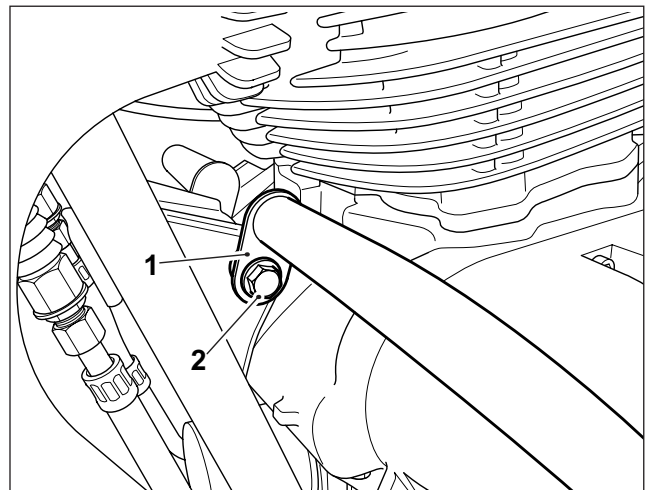

5 Align the bottom mounting of the engine guard (1) with the lower engine mounting location on the motorcycle frame (2), as shown. Fit a M10 x 52 mm fixing (3) from the kit with an original washer (4) and nut (5).

While holding the nut with a suitable spanner, tighten the fixing to **45Nm**.

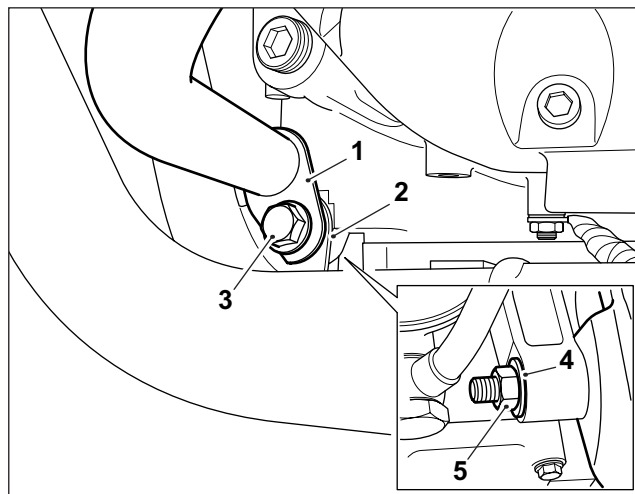

6 Fit the top mounting of the right hand engine guard (1) on to the engine mounting fixing (2) and refit the original nut (3) and washer (4) as shown.

Do not tighten the engine mounting fixing at this stage.

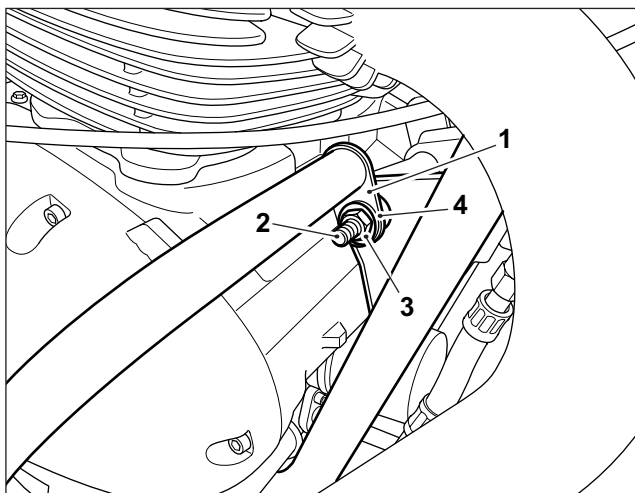

7 Align the bottom mounting of the engine guard (1) with the with the lower engine mounting location on the motorcycle frame (2). Fit the M10 x 45mm fixing (3) from the kit with the original washer (4) and nut (5).

While holding the nut with a suitable spanner, tighten the fixing to **45Nm**.

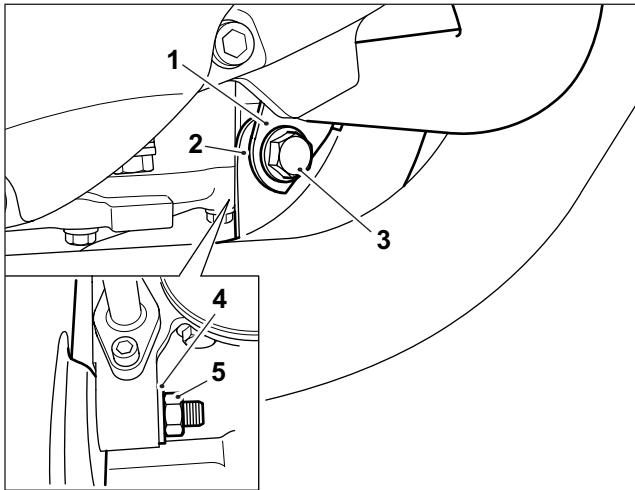

8 Tighten the top engine mounting fixing to **45Nm**.

⚠ WARNING: After fitting any genuine Royal Enfield accessory always ride the motorcycle with caution and allow time to become familiar with any change in the motorcycle handling characteristics. Failure to become familiar with any change in the motorcycle handling characteristics may cause the motorcycle to become unstable and result in an accident.